

Integrity with Hydraulic Seat

Product # LH: 71061 | RH: 71062

61" x 29 7/8" x 24" | Immersion Depth: 14"

DESIGN FEATURES

- Left or right inward door swing
- Electric hydraulic lift seat
- Maximum weight for the liftable seat: 200kgs
- Two switches controlling up & down motion of the Hydraulic Seat
- Water Capacity, only for reference: 62 US Gallons
- Drain included

JETTING UPGRADES

LATERAL AIR

16 Jet Air System

- White 00021
- Brushed Nickel 00023
- Polished Chrome 00024

AVAILABLE UPGRADES

- Chromotherapy
- Comfortwarm™
- Aromatherapy

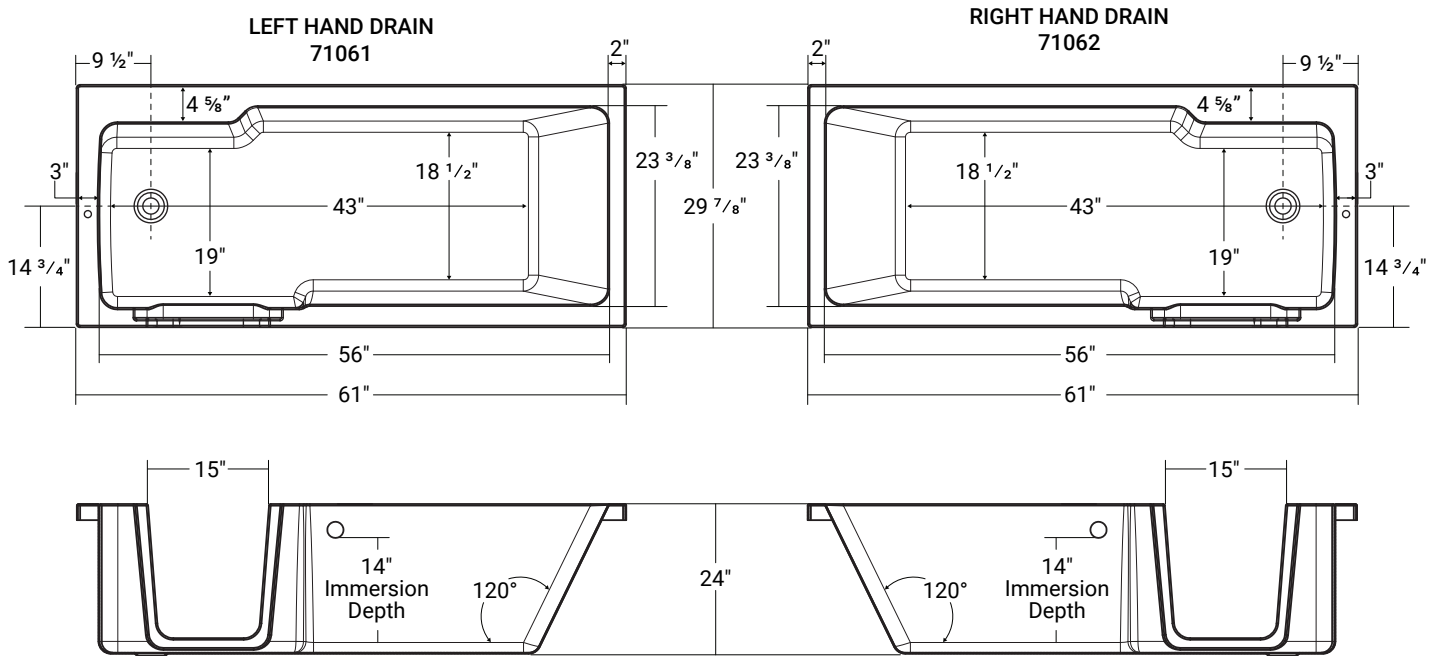

The product is approved under one of    

Acritec Industries Corp.
27049 Gloucester Way
Langley, B.C. V4W 3Y3

Tel: 604.607.0856
Fax: 604.607.0857
Email: info@acritec.com
Website: www.acritec.com

Important

*While we strive to provide accurate measurements for our customers, sometimes mistakes happen. Our goal is to help things run smoothly from shipment to installation, so if you notice any errors in our spec sheets, please let us know.

Our products are handmade & hand finished so you can expect a tolerance of $\pm \frac{1}{4}$ " on all measurements. We strongly recommend waiting until your ordered product is on-site before attempting any rough-in carpentry or plumbing.

If you want to verify any of our measurements, please feel free to call or email us.

*Drawings are not to scale

In keeping with our policy of continuing product improvement, Acritec Industries Corp. reserves the right to change product specifications without notice.